

Exhibit 2-14. Minimum Turning Path for Intermediate Semitrailer (WB-15 [WB-50]) Design Vehicle

12.0000

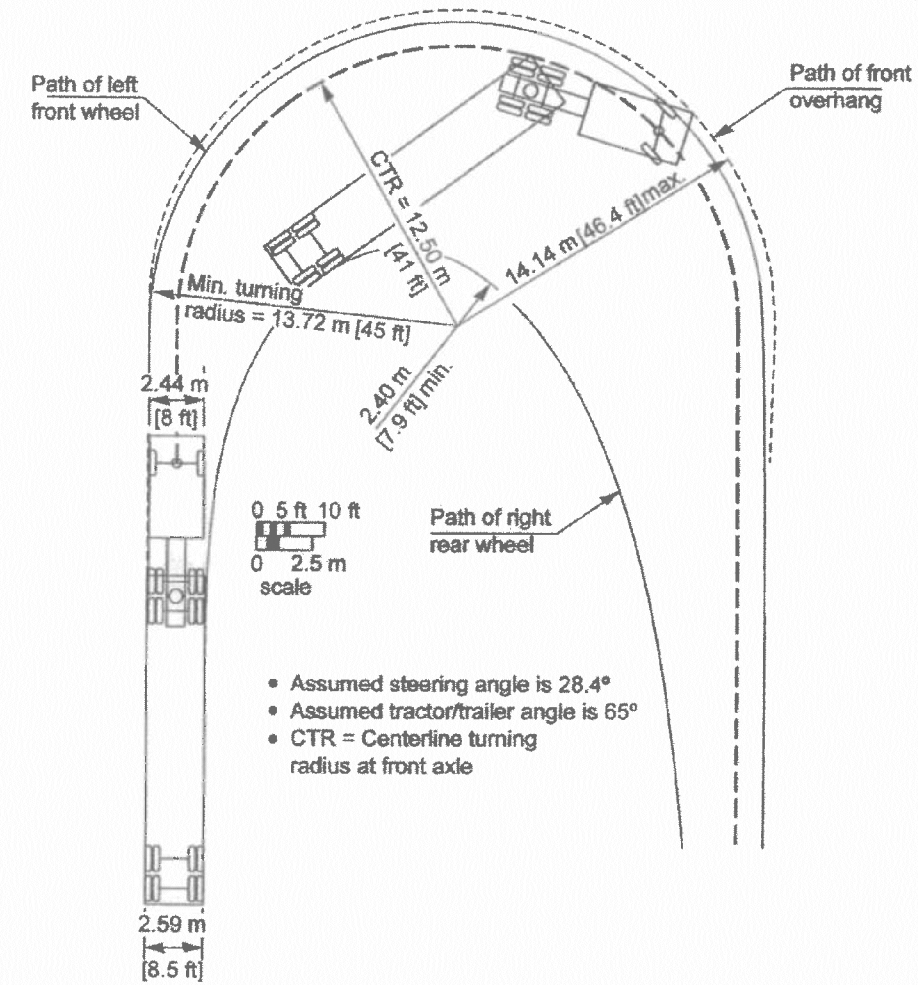
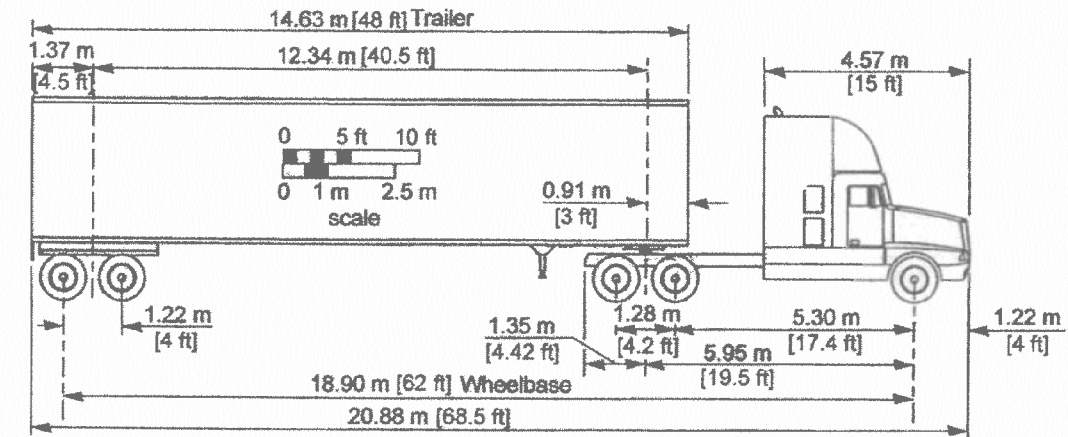

Exhibit 2-15. Minimum Turning Path for Interstate Semitrailer (WB-19 [WB-62]) Design Vehicle